



service information

ADVISORY
 BULLETIN

No. 2001-01

Circulate to: Sales Manager Accounting Service Manager Technician Parts Manager

Direct Injector Replacement Optimax

Models Affected

MERCURY/MARINER
2000 Model, 115 Thru 150 HP, 2.5 Litre Optimax
2001 Model, 135 Thru 225 HP, 2.5 and 3.0 Litre Optimax
Select Serial Number Groups

Some direct injectors used in the Optimax Outboards identified above may be subject to failure. An internal part of the injector could break resulting in hard starting, poor engine operation, and possible internal engine damage. Dealers are to contact the DIRECT INJECTOR ASSISTANCE TEAM at 1-800-309-4743 or, complete and send a QUICKFAX form (90-821655) to 1-800-842-4550 to receive pre-authorization and a set of replacement Direct Injectors.

DIRECT INJECTOR REPLACEMENT PROCESS

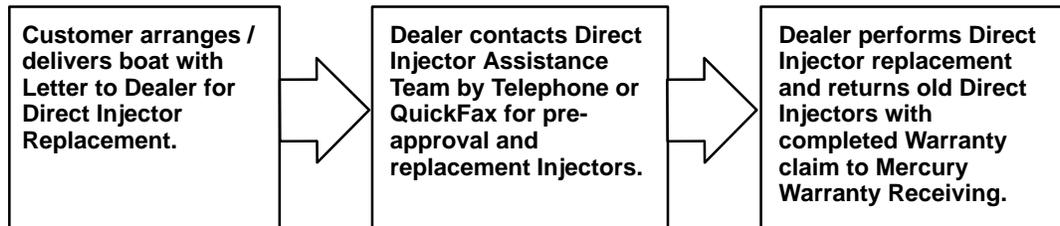

Owner Notification

A letter will be sent to every registered owner of an affected outboard. The letter will advise the owner to return their outboard to their selling dealer or any Mercury/Mariner authorized dealer for the replacement of the direct injectors. To show our confidence in the replacement injectors, and for the inconvenience on the part of the customer. Mercury Marine will add an additional three (3) months of factory limited warranty, for all engines registered to the customer before February 1, 2001, effective upon confirmation that the injectors have been replaced. (See customer letter attached)

Dealer Notification

Dealers with affected engines that were shipped directly from Mercury, will be notified individually.

Inspection

Before proceeding with the following correction, confirm that the work has **NOT** been completed prior to receiving the engine. Refer to the Midas system under engine history.

ENGINES RECEIVED FROM BOAT BUILDERS/OEM's: Refer to the Midas system under engine history for engines received from boat builder/OEM's to confirm if the rework is required.

ENGINE IN CARTON: If engine is in the carton, check for a BLUE dot near or on the serial number label. If BLUE dot is present, no further action is required because engine has been reworked at the factory.

ENGINE OUT OF CARTON: Check for BLUE paint dot on the direct injector opposite the electrical connection this can be seen from the side of the engine, looking between the rail and cylinder head, or look for the plastic part of the injector to be BLUE in color. BLUE paint dot or BLUE plastic housing indicates that the engine has the latest injector, and no further action is required.

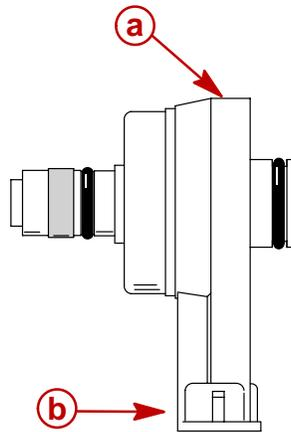

- a** - BLUE Paint Dot Location
- b** - Electrical Connection

Correction

Use the following steps if the engine requires replacement of the direct injector.

- Disconnect the battery voltage supply from engine.
- Remove the top cowl.
- Remove the two (2) nuts that retain one fuel rail.

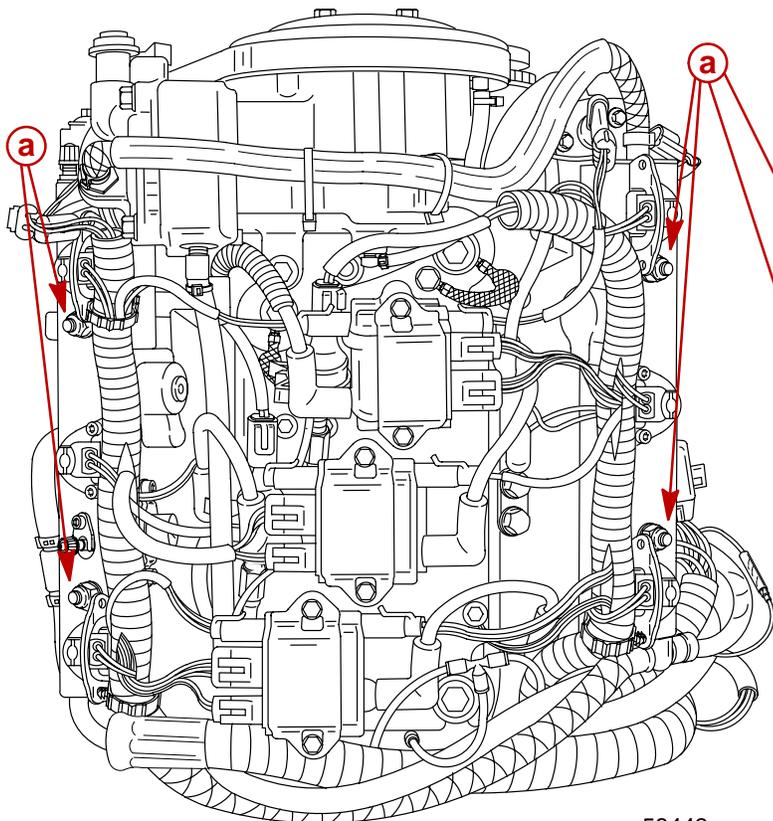

58443

135/150/175 DFI Powerhead Aft View

a - Fuel Rail Retainer Nuts

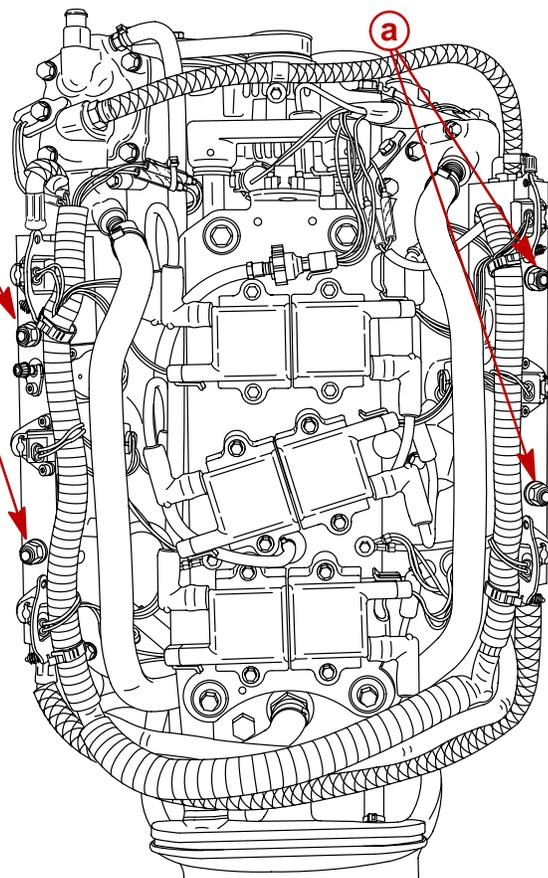

57785

200/225 DFI Powerhead Aft View

- Slide fuel rail to the rear/aft of engine until clearance to remove direct injectors is obtained.

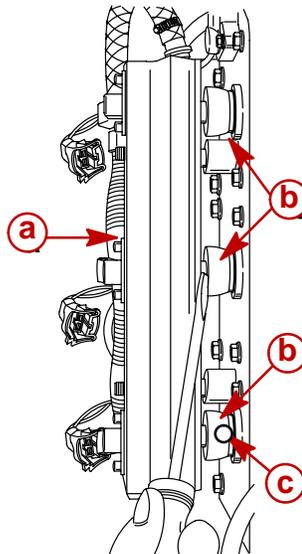

56121

- a** - Fuel Rail
- b** - Direct Injectors
- c** - BLUE PAINT DOT THIS LOCATION ON DIRECT INJECTOR

- Pull direct injector out of cylinder head or rail.

NOTE: Because these direct injectors must not be reused, they can be pried out of the head using two flat tip screw drivers. Normally any direct injector that is intended for reuse should be pulled out of the head straight, not pried out.

- After the injectors have been removed, disconnect the harness from the injector.
- Remove sizing bushing from new injector P/N 883078A1, apply 4 stroke oil to the O-rings, connect to the harness, and install injector into the cylinder head, repeat this process for the three injectors on that cylinder bank. Care must be taken to position the injector electrical connection in the correct direction.

NOTE: When the sizing bushing is removed from the injector the Teflon sealing ring will start to expand. If too much time is taken to install the injectors, installation may become difficult and/or damage to the sealing ring could occur. Removal of the sizing bushings, installation of injectors, and torque of the fuel rail nuts should occur within 3 minutes.

- The injector normally can not be pushed all the way into the cylinder head by hand with the rail still on the engine. Use the rail to push the injectors into the cylinder head. Push the rail ahead until the back/aft end of the injectors have entered the openings in the rail.
- Install the two nuts that retain the rail and evenly tighten ($\frac{1}{2}$ turn at a time) keeping the rail parallel to the cylinder head. This will push the injector into the cylinder head, then torque nuts to 33 lb. ft (44Nm).
- Repeat this process for the other cylinder bank.

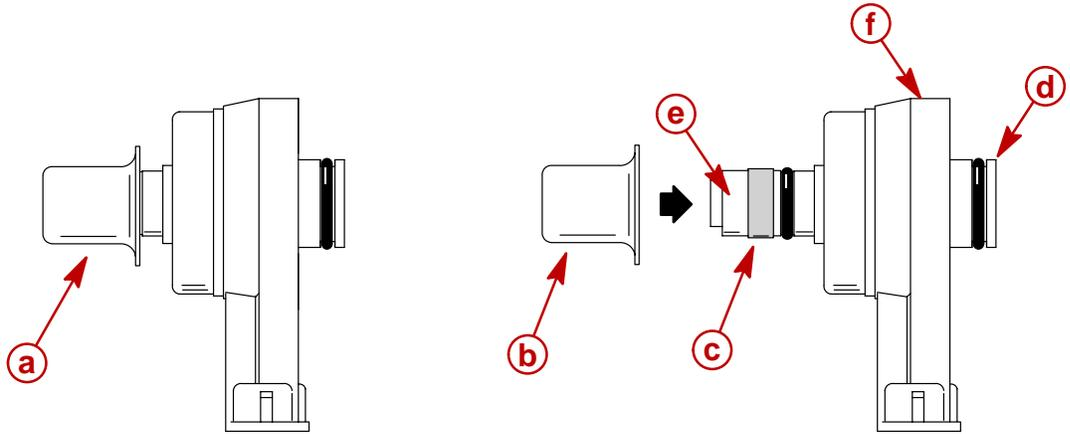

58587

- a** - Sizing Bushing Installed On Direct Injector
- b** - Sizing Bushing Removed
- c** - Teflon Seal
- d** - Rail End Of Injector
- e** - Cylinder Head End Of Injector
- f** - BLUE Paint Dot (Early Replacements)

- Connect battery supply to the engine
- Briefly run engine to confirm proper operation.

NOTE: Water must be supplied to the water pump impeller whenever engine is run.

Parts Required

Qty. Six (6) Direct Injectors – 883078A1

Warranty

Mercury Marine will credit the dealer for the cost of parts and labor to install the injectors for one year from the issuance of this bulletin. Please note the month and year located at the lower left corner of the front page of the bulletin

Service prior authorization is required, a claim will be created sent to the dealer, which includes the appropriate parts and labor.

US and CANADA: Complete/process warranty claim and return claim form with the old injectors that were removed from the engine..

INTERNATIONAL: Follow instructions issued by Marine Power International office or by your distributor.

January 24, 2001

Dear Valued Mercury Customer:

SUBJECT: DIRECT AIR INJECTOR REPLACEMENT

Thank you for your purchase of a Mercury OptiMax. We recognize that today's outboard engine is a large investment. That is why we are working to maximize your satisfaction with your outboard every time you turn the key. In partnership with one of our suppliers, Mercury has recently discovered that some of the direct air injectors on your engine may experience a failure that could render your engine inoperable. However, we want to minimize the likelihood of this failure on your outboard, and the only way to do that is to install a set of updated direct air injectors on your engine as soon as possible. We want to act immediately to minimize disruption to your boating and fishing time.

We at Mercury have worked with our dealer network to make sure that having the new direct air injectors installed in your engine will be as simple and quick for you as possible. All you need to do is contact your authorized Mercury Marine dealer, preferably the one who sold you the engine, and make arrangements to have the new direct air injectors installed. You must deliver your engine to your dealer to have the upgrade performed. We have arranged to have the replacement injectors shipped so that they will be available at the dealer for a timely upgrade, and our dealers are ready to make sure you are back on the water as quickly as possible. In the event that your boat is in storage, you may wish to wait until you remove it from storage to have this service performed.

Mercury will perform the direct air injector replacement on your OptiMax free of charge (parts and installation labor).

To show our confidence in the replacement injectors, and for your inconvenience, Mercury Marine will add an additional three (3) months of factory limited warranty, if your engine/s were registered before February 1, 2001. This additional warranty would be effective upon confirmation that the injectors have been replaced.

Should you have any questions related to this replacement, please do not hesitate to call our Direct Injector Assistance Team at 1-800-309-4743. This group has been specifically established to assist with the OptiMax direct air injector replacement, and they are ready to address any questions you may have.

We apologize for any inconvenience this replacement may have caused you; however, we are taking this action to ensure your boating and fishing time continues to be relaxing and enjoyable.

Sincerely,

Mercury Technical Service Department