

NUMBER: 82-1

DATE: 1/22/82

- A. Power Trim Cylinder Repair Tool - P/N 91-89671A1
- B. Fuel Filter "O" Ring - P/N 25-98277
- C. Carburetor Fittings - Fuel Enrichener
- D. Cowl Removal - 1982 V200
- E. Torque - Merc 40/50/70 Gear Housing Cover Nut

CIRCULATE TO:  
SERVICE MANAGER  
PARTS MANAGER  
MECHANICS

## A. POWER TRIM CYLINDER REPAIR TOOL - P/N 91-89671A1

Piston Guide Tool (91-89671A1) is available to assist in the reassembly of the shock piston assembly when installing "O" Ring Kits (25-69387A1) into the dual Power Trim cylinders of V6 Outboards. Instructions for use of this tool are included in the "O" Ring Kit.

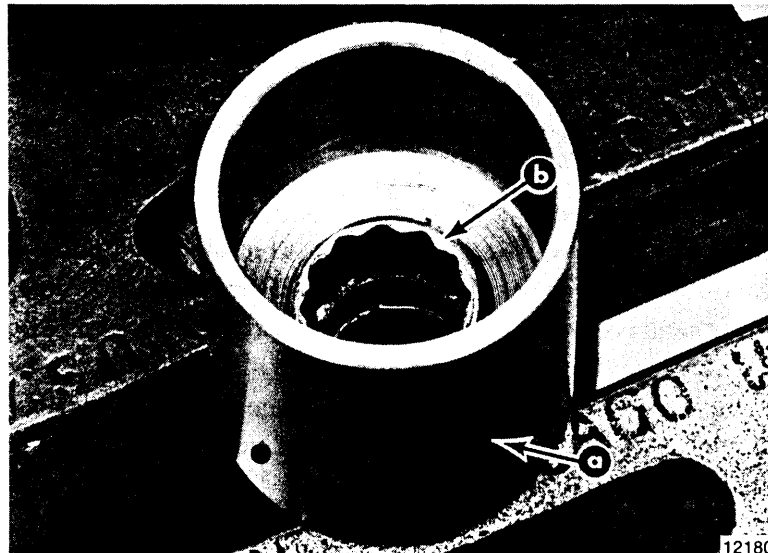

a - Piston Guide Tool

b - 5/8" Standard Short Socket

**Figure 1. Piston Guide Tool**

91-89671A1

Piston Guide Tool

## B. FUEL FILTER "O" RING - P/N 25-98277

A replacement "O" ring is now available for fuel filter assembly(s) 35-87946A1, 35-87946A2 and 35-87946A6.

25-98277

Fuel Filter "O" Ring

## C. CARBURETOR FITTINGS - FUEL ENRICHENER

The "T" fitting and 90° elbow carburetor fuel line connectors (Figure 2) used on those outboards equipped with the fuel enricheners are now in service replacement stock. Order Part Numbers:

1395-8206

90° Fitting

1395-8207

"T" Fitting

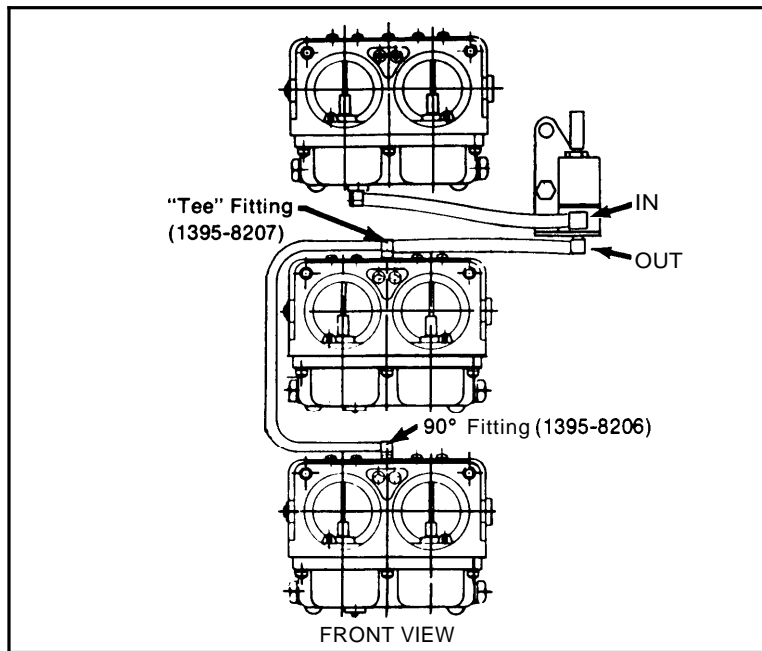

**Figure 2. Enrichener Fittings**

#### D. COWL REMOVAL - 1982 V200

The 1982 V200 Outboard has a safety catch on the cowl latch which makes it difficult to release the cowls when the outboard is on the shipping skid. After removal of the front cowl (DO NOT cut the band around the drive shaft housing until after the lift ring and engine hoist have been installed) it may be necessary to release cowl latch with a rod or large screwdriver. Reach under powerhead and release the cowl latch (Figure 3) and remove the cowls. Then install lifting eye and engine hoist, cut band from drive shaft housing and carefully lift outboard away from shipping skid.

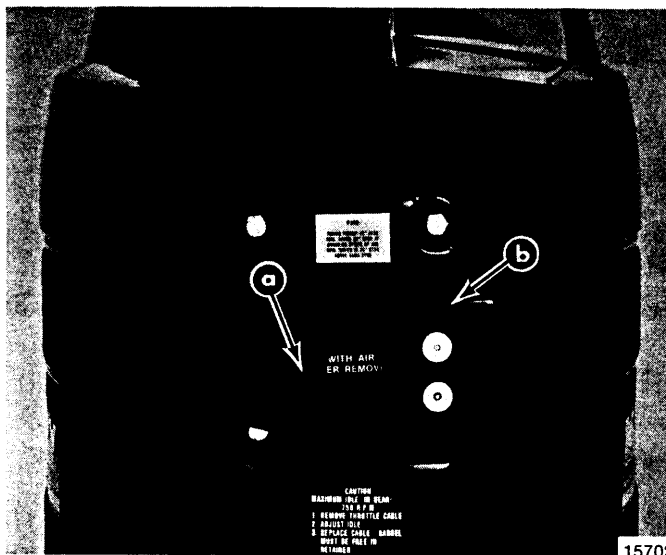

a - Inner Cowl Latch (Push in where shown)

b - Outer Cowl Latch

**Figure 3. Releasing Cowl Latch**

#### E. TORQUE - MERC 40/50/70 GEAR HOUSING COVER NUT

Torque specifications in the Service Manual mistakenly call for a torque of 210 lb. ft. on the plastic gear housing cover nut on the Merc 40/50/70 Outboards. The correct torque specification for the gear housing cover nut is 100 lb. ft. Coat threads of nut with Perfect Seal (P / N 92-34227) and torque to 100 lb. ft. (135.6 N.m) with Tool (P/N 91-91947).